



**THE TRAFFIC REGULATIONS 1976, AMENDMENT NO. 29**

---

MICHAEL HARDIE BOYS, Governor-General

ORDER IN COUNCIL

At Wellington this 18th day of November 1996

Present:

HIS EXCELLENCY THE GOVERNOR-GENERAL IN COUNCIL

PURSUANT to sections 77 and 199 of the Transport Act 1962, His Excellency the Governor-General, acting by and with the advice and consent of the Executive Council, hereby makes the following regulations.

---

ANALYSIS

- |  |  |
|--|--|
| 1. Title and commencement                                    | 7. Issue of warrants of fitness, certificates of fitness, certificates of loading, and permits |
| 2. Overtaking  | 8. Warnings to be painted on road surface  |
| 3. Railway crossings   | 9. Cross-hatching may be marked on level crossing  |
| 4. Restrictions on stopping or parking vehicles              | 10. Warning signs  |
| 5. Safety helmets for cyclists                               | 11. Support for traffic signs  |
| 6. Revocation of regulations relating to glazing of vehicles | 12. Third Schedule amended   |
|  | 13. Fourth Schedule amended Schedules  |
- 

REGULATIONS

**1. Title and commencement**—(1) These regulations may be cited as the Traffic Regulations 1976, Amendment No. 29, and shall be read

together with and deemed part of the Traffic Regulations 1976\* (hereinafter referred to as the principal regulations).

(2) Except as provided in subclause (3) of this regulation, these regulations shall come into force on the 1st day of January 1997.

(3) Regulation 5 of these regulations, so far as it relates to subclause (5) of regulation 38A of the principal regulations (as substituted by that regulation 5), shall come into force on the 25th day of November 1996.

**2. Overtaking**—Regulation 8 of the principal regulations is hereby amended by revoking subclause (5), and substituting the following subclauses:

“(5) No driver shall pass or attempt to pass another vehicle which has stopped at a level crossing to give way to any rail service vehicle using the railway line.

“(5A) No driver shall pass or attempt to pass another vehicle moving in the same direction at or within 60m of a level crossing unless, where the roadway is marked in lanes, the driver’s vehicle does not encroach on a lane available for opposing traffic.”

**3. Railway crossings**—Regulation 11 of the principal regulations is hereby amended by inserting, after subclause (1), the following subclause:

“(1A) Every driver approaching any level crossing which is controlled by a give-way sign shall give way to any rail service vehicle which is approaching or crossing the level crossing.”

**4. Restrictions on stopping or parking vehicles**—Regulation 35 (2) of the principal regulations is hereby amended by adding, after paragraph (m), the following paragraph:

“(n) Near a level crossing so as to obscure the view that other drivers have of the crossing or a rail service vehicle approaching the crossing.”

**5. Safety helmets for cyclists**—Regulation 38A of the principal regulations (as inserted by regulation 2 of the Traffic Regulations 1976, Amendment No. 24) is hereby amended by revoking subclauses (4) and (5), and substituting the following subclauses:

“(4) For the purposes of this regulation, the expression ‘safety helmet of an approved type’ means a safety helmet of a type that is approved by the Director under subclause (5) of this regulation.

\*S.R. 1976/227

- Amendment No. 1: S.R. 1978/72
- Amendment No. 2: (Revoked by S.R. 1984/169)
- Amendment No. 3: (Revoked by S.R. 1980/115)
- Amendment No. 4: S.R. 1980/31
- Amendment No. 5: S.R. 1980/115
- Amendment No. 6: S.R. 1981/158
- Amendment No. 7: S.R. 1981/311
- Amendment No. 8: S.R. 1982/93
- Amendment No. 9: S.R. 1983/282
- Amendment No. 10: S.R. 1984/31
- Amendment No. 11: S.R. 1984/169
- Amendment No. 12: S.R. 1985/70
- Amendment No. 13: S.R. 1985/144
- Amendment No. 14: S.R. 1985/289
- Amendment No. 15: S.R. 1987/213
- Amendment No. 16: S.R. 1988/171
- Amendment No. 17: S.R. 1988/187
- Amendment No. 18: S.R. 1988/326
- Amendment No. 19: (Revoked by S.R. 1990/333)
- Amendment No. 20: S.R. 1989/312
- Amendment No. 21: S.R. 1990/159
- Amendment No. 22: S.R. 1990/333
- Amendment No. 23: S.R. 1992/184
- Amendment No. 24: S.R. 1993/176
- Amendment No. 25: S.R. 1993/295
- Amendment No. 26: S.R. 1994/31
- Amendment No. 27: S.R. 1994/312
- Amendment No. 28: S.R. 1996/43

“(5) The Director may,—

“(a) With effect on the 1st day of January 1997; or

“(b) From time to time, with effect on any date after the 1st day of January 1997,—

by notice in the *Gazette*, approve types of safety helmets for use under this regulation.

“(6) Any person who, before the date on which any *Gazette* notice given by the Director under subclause (5) of this regulation comes into force, has purchased a helmet that was a safety helmet of an approved type for the purposes of this regulation immediately before that *Gazette* notice came into force may, unless the notice specifies otherwise, after that *Gazette* notice comes into force, continue to use that safety helmet for the purposes of this regulation.”

#### **6. Revocation of regulations relating to glazing of vehicles—**

(1) The principal regulations are hereby amended by revoking regulation 73 (4), (5), and (6) and regulation 73A.

(2) The following regulations are hereby consequentially revoked.

(a) Regulation 17 of the Traffic Regulations 1976, Amendment No. 4:

(b) Regulation 6 of the Traffic Regulations 1976, Amendment No. 10:

(c) Regulation 5 of the Traffic Regulations 1976, Amendment No. 12.

#### **7. Issue of warrants of fitness, certificates of fitness, certificates of loading, and permits—**

(1) Regulation 84 of the principal regulations (as substituted by section 35 (3) of the Land Transport Act 1993) is hereby amended by inserting, at the beginning of subclause (21), the words “Except as provided in subclauses (21A) and (21B) of this regulation,”.

(2) Regulation 84 of the principal regulations (as so substituted) is hereby further amended by inserting, after subclause (21), the following subclauses:

“(21A) Subclause (21B) of this regulation applies to a vehicle that is—

“(a) A class MA vehicle (within the meaning of the Transport (Vehicle Standards) Regulations 1990); and

“(b) A rental service vehicle (as defined in section 2 of the Transport Services Licensing Act 1989)—

where a certificate of fitness in respect of the vehicle is being issued at the time of the first registration of the vehicle.

“(21B) A vehicle to which this subclause applies shall be exempted from subclause (21) of this regulation subject to the following conditions:

“(a) The date of expiry to be entered on the certificate of fitness by the person issuing it shall be not more than 12 months from the date of the examination; and

“(b) If, at any time after the issue of the certificate of fitness and before the date of expiry of the certificate of fitness, the vehicle—

“(i) Is modified; or

“(ii) Suffers significant accident damage; or

“(iii) Travels more than a total of 50,000 kilometres,—

the exemption conferred by this subclause shall cease to have effect and the certificate of fitness shall be deemed to have expired on the date on which the vehicle was modified or damaged or the date on which the 50,000 kilometres travelled was attained, as the case may be; and

“(c) Subclause (21) of this regulation shall apply to the issue of any certificate of fitness in respect of the vehicle subsequent to the certificate of fitness referred to in subclause (21A) of this regulation.”

**8. Warnings to be painted on road surface**—Regulation 106 of the principal regulations is hereby amended by adding, after subclause (4), the following subclauses:

“(5) At any level crossing where—

“(a) The road approaching the level crossing is subject to a speed limit of 70 kilometres an hour or more; or

“(b) Traffic approaches the level crossing in more than one lane,—the controlling authority shall, if the road surface permits it, mark on the road surface, in accordance with subclause (6) of this regulation, the expressions ‘Rail’ and ‘X’.

“(6) The road markings required by subclause (5) of this regulation shall—

“(a) Be made using reflectorised material in letters of at least 2.4m high and in the form described in diagram No. 4 in the Third Schedule to these regulations; and

“(b) Be located—

“(i) Where both sign P41 and sign P44 as described in the Fourth Schedule to these regulations are erected, approximately 15m after sign P44; or

“(ii) Where only sign P44 is erected, approximately 10m before that sign.

“(7) At any level crossing on any road to which neither paragraph (a) or paragraph (b) of subclause (5) of this regulation applies, the controlling authority may, if in its opinion additional indication to drivers is desirable, mark on the road surface the markings described in subclause (5) of this regulation in the manner described in subclause (6) of this regulation.”

**9. Cross-hatching may be marked on level crossing**—The principal regulations are hereby amended by inserting, after regulation 106, the following regulation:

“106A. A controlling authority may, if in its opinion it is desirable, mark on the road surface of a level crossing cross-hatching, using yellow reflectorised material, in the form described in diagram No. 5 in the Third Schedule to these regulations to indicate the area that a driver shall not enter when the driver’s intended passage through that area is blocked by stationary traffic.”

**10. Warning signs**—Regulation 124 of the principal regulations is hereby amended by revoking subclause (1), and substituting the following subclauses:

“(1) Every controlling authority shall erect such warning signs before a level crossing as it considers necessary to inform drivers of the level crossing and to promote safe responses from drivers approaching and crossing the level crossing.

“(1A) Every controlling authority shall erect the appropriate warning signs at or near to any entrance to a school for children, a kindergarten, a pre-school centre, a hospital, or any other place of any kind whatsoever where in the opinion of the controlling authority special watchfulness, caution, or slowness of speed on the part of the driver of a motor vehicle is required.”

**11. Support for traffic signs**—Regulation 131 of the principal regulations is hereby amended by inserting, after subclause (4), the following subclauses:

“(4A) Notwithstanding subclause (2) or subclause (3) of this regulation, the following signs may be erected on the same pole at a level crossing:

“(a) A give-way sign or a stop sign; and

“(b) A crossbuck sign; and

“(c) Where appropriate, a ‘look for trains’ sign or a ‘more than 1 track’ sign, or both.

“(4B) Notwithstanding subclause (1) or subclause (2) or subclause (3) of this regulation, the following signs may be erected on the same pole as a traffic signal at a level crossing:

“(a) A crossbuck sign; and

“(b) Where appropriate, a ‘stop on red signal’ sign or a ‘more than 1 track’ sign, or both.”

**12. Third Schedule amended**—The Third Schedule to the principal regulations is hereby amended by adding, after diagram No. 3, the diagrams set out in the First Schedule to these regulations.

**13. Fourth Schedule amended**—(1) Part II of the Fourth Schedule to the principal regulations (as substituted by regulation 6 (1) of the Traffic Regulations 1976, Amendment No. 17) is hereby amended by revoking the item relating to sign P39, and substituting the item set out in Part I of the Second Schedule to these regulations.

(2) Part II of the Fourth Schedule to the principal regulations (as so substituted) is hereby further amended by omitting from the item relating to sign P40 (as substituted by regulation 14 of the Traffic Regulations 1976, Amendment No. 27) all the words relating to sign (a).

(3) The Fourth Schedule to the principal regulations (as so substituted) is hereby amended by inserting in Part II, after the item relating to the sign P40, the items set out in Part II of the Second Schedule to these regulations.

(4) Part III of the Fourth Schedule to the principal regulations (as so substituted) is hereby amended by omitting from the first column of the item relating to sign R1 the words “(meaning set out in regulation 9 (2))”, and substituting the words “(meaning set out in regulations 9 (2) and 11 (1A))”.

(5) Notwithstanding anything in this regulation, until the 31st day of December 2000, it shall be sufficient compliance with the requirements of regulation 129 of the principal regulations in relation to railway crossings if instead of the corresponding signs as inserted by subclause (3) of this regulation, the sign revoked by subclause (2) of this regulation is erected.

---

SCHEDULES

FIRST SCHEDULE

Reg. 12

AMENDMENTS TO THIRD SCHEDULE TO PRINCIPAL REGULATIONS

Reg. 106 (5)

Diagram No. 4

WARNING MARKING FOR LEVEL CROSSING

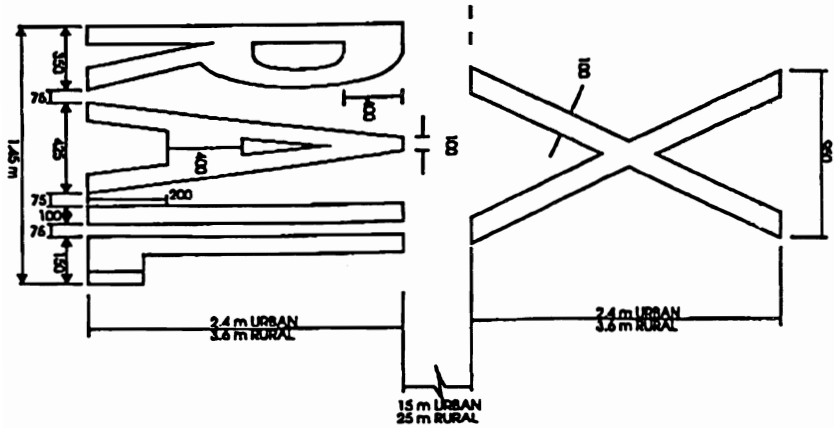

Reg. 106A

Diagram No. 5

CROSS-HATCHING

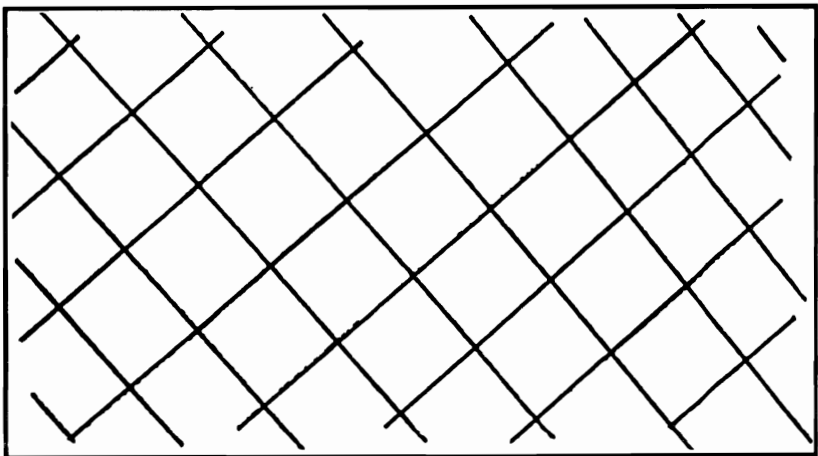

Size of diamond to be  $\frac{W}{2}$ , where W = the lane width.

Width of lines to be 100 mm.

SECOND SCHEDULE  
 AMENDMENTS TO FOURTH SCHEDULE TO PRINCIPAL REGULATIONS  
 PART I

Reg. 13

Name of Sign (meaning of sign in brackets)	Shape and Size	Background Colour	Border	Legend	Colour and Size
	Other Requirements, Associated Signs, Etc.				
P39. Railway Crossing (railway level crossing)	'Crossbuck' consisting of one board 1000 mm long by 200 mm wide, sloping downwards to the right at 30° to the horizontal in front of a similar board of the same size sloping downwards to the left at 30° to the horizontal Note: (1) To be erected on all roads crossed by a railway line. (2) May be mounted on a red reflectorised rectangular backing board.	White(r)	None	'CROSSING' on front board 'RAIL' 'WAY' on rear board	Black, 135/21 Black, 135/19
		Red(r)	White(r)		

1996/388

Traffic Regulations 1976, Amendment No. 29

1751

SECOND SCHEDULE—*continued*  
 AMENDMENTS TO FOURTH SCHEDULE TO PRINCIPAL REGULATIONS—*continued*  
 PART II

Name of Sign (meaning of sign in brackets)	Shape and Size	Background Colour	Border	Legend	Colour and Size
	Other Requirements, Associated Signs, Etc.				
P41. "Level Crossing Ahead" (intermediate warning of level crossing)	Diamond, 600 mm	Yellow(r)	Black, 15 mm	Symbol of railway crossing road	Black
P42. "Look for Trains" (warning drivers to check for trains)	Square, 600 mm	Yellow(r)	Black, 15 mm	"Look for Trains" with arrow indicating away from each side of "for"	Black
P43. "Railway Flashing Light Ahead" (warning to look for flashing lights at level crossing)	Diamond, 600 mm	Yellow(r)	Black, 15 mm	Symbol of crossbuck railway sign and signal head on a post	Black
P44. "Level Crossing Warning" (advance warning of level crossing)	Diamond, 600 mm	Yellow(r)	Black, 15 mm	Symbol of a steam train	Black
P45. "Stop On Red Signal" (warning drivers to stop when signal shows red)	Square, 600 mm	White(r)	Red(r)	"STOP ON RED SIGNAL"	Black, 100/16

MARIE SHROFF,  
 Clerk of the Executive Council.



## EXPLANATORY NOTE

*This note is not part of the regulations, but is intended to indicate their general effect.*

These regulations, which come into force on 1 January 1997, make various amendments to the Traffic Regulations 1976.

*Regulation 2* amends regulation 8 of the principal regulations (which relates to overtaking) to impose new restrictions on overtaking near to a level crossing.

*Regulation 3* amends regulation 11 of the principal regulations (which relates to railway crossings) to provide that a driver approaching a level crossing controlled by a give-way sign shall give way to any rail service vehicle approaching or crossing the level crossing.

*Regulation 4* amends regulation 35 of the principal regulations (which relates to restrictions on stopping or parking vehicles) to prohibit stopping or parking of a vehicle near a level crossing so as to obscure the view that other drivers have of the crossing.

*Regulation 5* amends regulation 38A of the principal regulations (which relates to safety helmets for cyclists). Presently, regulation 38A lists certain approved safety helmets and provides that after 31 December 1996 the Director of Land Transport Safety shall only approve helmets that comply with a New Zealand Standard.

The effect of the amendments is that from 1 January 1997 the Director may approve standards for helmets by notice in the *Gazette*. A transitional provision provides that a person who purchased a safety helmet before a *Gazette* notice came into force, that was at the time of purchase an approved helmet, may continue to use that helmet.

*Regulation 6* revokes certain provisions of the Traffic Regulations 1976 which relate to the glazing of vehicles.

The revocation is a consequence of the making under Part II of the Land Transport Act 1993 of the new Land Transport Rule 32012—Vehicle Standards (Glazing) notified in the *Gazette* of 12 September 1996.

The revocation takes effect on 1 January 1997, the same date as the new Rule comes into force.

*Regulation 7* amends regulation 84 of the principal regulations (which relates to the issue of warrants of fitness, certificates of fitness, certificates of loading, and permits). The amendment exempts brand new class MA rental service vehicles from the requirement under regulation 84 (21) to have a certificate of fitness inspection 6 months after the first certificate of fitness is issued on the first registration of the vehicle. The exemption is subject to certain specified conditions.

*Regulation 8* amends regulation 106 of the principal regulations (which relates to warnings to be painted on road surfaces) to provide for signs to be marked on the road near a level crossing in certain circumstances.

*Regulation 9* inserts a new regulation 106A into the principal regulations which provides that a controlling authority may, if it thinks it is desirable, mark cross-hatching on the road surface of a level crossing.

*Regulation 10* amends regulation 124 of the principal regulations (which relates to warning signs). New subclauses (1) and (1A) are substituted. *Subclause (1)* provides that a controlling authority shall erect such warning signs before a level crossing as it considers necessary to alert drivers and to promote safe responses from drivers at and near the crossing. *Subclause (1A)* is in the same terms as the existing regulation 124 (1) (b).

*Regulation 11* amends regulation 131 of the principal regulations (which relates to support for traffic signs). It provides that a number of signs relating to a level crossing may be erected on the same pole.

*Regulation 12* amends the Third Schedule to the principal regulations to insert diagrams of the warning marking and the cross-hatching marking for level crossings.

*Regulation 13* amends the Fourth Schedule to the principal regulations in relation to railway signs. The specification for the “crossbuck” sign is altered by reducing the minimum required dimensions of the sign. The “RAILWAY” sign is revoked and 5 new signs relating to level crossings are inserted. Regulation 124 of the principal regulations, as amended by regulation 10 of these regulations, requires every controlling authority to erect such warning signs before a level crossing as it considers necessary. Under regulation 129 of the principal regulations those warning signs must comply with the appropriate description given in the Fourth Schedule. The new signs inserted by these regulations are the approved warning signs. A transitional provision provides that until 31 December 2000 the use of “RAILWAY” signs

will be sufficient compliance with the regulations, to allow time for controlling authorities to replace those signs.

---

Issued under the authority of the Acts and Regulations Publication Act 1989.

Date of notification in *Gazette*: 21 November 1996.

These regulations are administered in the Ministry of Transport.